

PHOENIX GEOPHYSICS INC.

REPORT ON THE  
RESISTIVITY SURVEY  
OF THE  
SAN EMIDIO AREA  
WASHOE COUNTY, NEVADA  
FOR  
CHEVRON OIL COMPANY.

8/76

PHOENIX GEOPHYSICS INC.

REPORT ON THE  
RESISTIVITY SURVEY  
OF THE  
SAN EMIDIO AREA  
WASHOE COUNTY, NEVADA  
FOR  
CHEVRON OIL COMPANY

---

1. INTRODUCTION

At the request of Mr. Robert Edmiston, geophysicist with Chevron Oil Company, Phoenix Geophysics has completed a Resistivity Survey in the San Emidio area, Washoe County, Nevada. The survey area is located in T.29N. and R.23E. of Washoe County.

A previous resistivity survey was conducted in this area by McPhar Geophysics during the latter part of 1973. This survey was conducted mainly along north-south lines spaced one mile apart employing 2000 foot dipoles. Two narrow, elongated, anomalies were interpreted from the survey results, having a true resistivity less than three ohm meters.

The purpose of this Resistivity survey was to provide detailed information on the shallow resistivity response across the previously located anomalous areas. Measurements were made with 500 foot dipoles at one-through-six dipole separations along east-west lines approximately one-half mile apart. A frequency of 0.125 Hz was used in order to minimize attenuation of the electric field due to eddy current dissipation of energy and at the same time avoid telluric noise.

The survey was supervised and conducted by Mr. John Reynolds, geologist, during the period May 23 to May 27, 1976. A transmitted current between 4 amps and 15 amps was required to obtain voltage readings varying between 45 microvolts and 240 millivolts.

## 2. PRESENTATION OF RESULTS

The resistivity survey results are shown on the following data plots in the manner described in the notes which accompany this report.

<u>Line</u>	<u>Electrode Intervals</u>	<u>Dwg. No.</u>
SE-76-1	500 foot	R-U-5012-1
SE-76-2	500 foot	R-U-5012-1
SE-76-3	500 foot	R-U-5012-2
SE-76-4	500 foot	R-U-5012-2

Also enclosed with this report is Dwg. No. RP-U-5012, a plan map of the survey area at a scale of 1" = 500' showing the location of the survey lines and an interpreted true resistivity section along each survey line. The definite, probable and possible Resistivity low anomalies are indicated by bars, in a manner shown in the legend, on the plan map as well as on the data plots. These bars represent the surface projection of the anomalous responses as interpreted from the location of the transmitter and receiver electrodes when the anomalous values were measured. The interpreted true resistivity sections along each survey line have been compiled with the aid of two-dimensional theoretical curves, three dimensional model studies, and a computer program for the direct inversion of apparent resistivity data for layered media.

Since the Resistivity measurements is essentially an averaging process, as are all potential methods, it is frequently difficult to exactly pinpoint the source of an anomaly. Certainly, no anomaly can be located with more accuracy than the electrode interval length. In order to locate sources at some depth,

larger electrode intervals must be used, with a corresponding increase in the uncertainties of location. Therefore, while the center of the indicated anomaly probably corresponds fairly well with source, the length of the indicated anomaly along the line should not be taken to represent the exact edges of the anomalous material.

The anomalies shown on the plan map are designated apparent depths of shallow, moderate, or deep. At larger dipole separations a greater volume of rock is averaged, in lateral extent as well as depth. Thus, the source of a deep-appearing anomaly detected along a single line may be at shallow depth to one side of the line. The data plots, therefore, cannot represent true depth. Depths can be calculated from the apparent resistivity data in the case of ideal horizontal layers, but even this calculation depends on an assumed resistivity contrast between the zone at depth and the overlying rock. Although ambiguous, the following simple depth designations are useful for correlating or comparing anomalous zones obtained on adjacent survey lines.

	Apparent Depth (dipole separations)	Drill Hole Depth (in dipole lengths)
Shallow	1 - 2	1/2 - 1
Moderate	2 - 3	1 - 1-1/2
Deep	3 - 5	1-1/2 - 2+

Thus, a shallow zone is one detected at a one-to-two dipole separation and should be tested by a drill hole from a half-to-one dipole length deep.

### 3. DISCUSSION OF RESULTS

Almost the entire survey area exhibits definite anomalous responses which have a true resistivity less than three ohm meters. Generally, the anomalous area is limited on the east side by the 4200 foot elevation contour, and extends beyond the west end of each line across the San Emidio Desert.

The 500 foot dipole data corresponds to the results of the previous resistivity survey and also provides more detailed information on the near surface resistivity features. A discussion of the survey results along each line follows.

Line SE-76-1

The areas of low resistivity, less than three ohm meters, located along this line between 190E to 170E and 160E to beyond 100E, are separated by a shallow resistivity high, centered at approximately 165E. This high is almost coincident with a road, but probably is not the result of any cultural effects since similar responses are not observed on any of the other lines.

The resistivity pattern between 100E and 140E is very uniform and indicates a simple two-layered earth.

The east end of this line shows an increase in resistivity corresponding to topographic expression, but no faulting is indicated on this data.

Line SE-76-2

A conductive layer, with a true resistivity of less than two ohm meters, extends along this line from 195E to beyond 95E. This definite anomaly is relatively shallow, varying from approximately 250 feet deep beneath 135E and 140E to approximately 750 feet beneath 105E.

There is some variation in the near-surface resistivities above the anomaly and a fault or contact occurs in the vicinity of 210E separating higher resistivities on the east from the low resistivities of the conductive area.

Line SE-76-3

The apparent resistivity data from 180E to 100E is generally quite uniform, suggesting a comparatively simple layered earth. Slight increases in the near surface resistivities occur between 180E to 160E and 150E to 135E,

and there are also variations at depth within the anomalous area, between 105E and 150E.

A possible contact occurs in the vicinity of 210E closing off the definite anomaly on the east end.

Line SE-76-4

This line was previously surveyed in 1973 with 2000 foot dipoles, and an attempt was made to occupy similar electrode locations during this survey.

The previous data located a definite anomaly from 60E to 170E. This anomaly appeared quite uniform and simple. The 500 foot dipole data shows that this anomaly exhibits some variations not previously seen. The interpreted definite anomalies appear comprised of areas of high but variable conductivity. The lowest, true resistivity responses are centered beneath 130E and 160E at moderate depth.

The extremely uniform resistivity to the west of station 100E, apparently from the previous survey results, decreases at depth below the detection limits of this survey; thus possibly the low resistivities beneath 130E are representative of the deeper source previously located.

4. CONCLUSION AND RECOMMENDATIONS

The 500 foot dipole-dipole resistivity data has confirmed that an area of low resistivity exists within the survey area, but the anomalous zone does not appear to be two separate elongated zones as previously reported.

Almost the entire length of each of the four survey lines is underlain at varying depths by a very conductive layer having a true resistivity of less than three ohm meters. The eastern end of this anomalous zone has been defined but it is still open to the west, north and south.

The apparent resistivity data exhibits near horizontal contours throughout parts of the anomalous area, but there is also sufficient lateral

variations within each anomaly to suggest that the conductive zone is not due entirely to conductive sediments.

Since several areas of lowest resistivity occur within 500 feet of the surface, some temperature gradient and/or geological investigative holes should be drilled to confirm that this anomalous zone is due to increased temperature gradients. Drill test holes should be located at the following locations:

Line SE-76-4 beneath 130E

Line SE-76-1 beneath 185E

Line SE-76-2 beneath 130E

If the results of the test drilling are encouraging, additional resistivity work may be required to determine the full extent of this anomalous zone.

PHOENIX GEOPHYSICS INC.

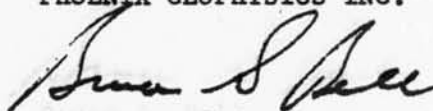

Bruce S. Bell  
Geologist

July 9, 1976

PHOENIX GEOPHYSICS INC.

ADDENDUM TO THE REPORT  
ON THE  
RECONNAISSANCE RESISTIVITY SURVEY  
OF THE  
SAN EMIDIO AREA  
WASHOE COUNTY, NEVADA  
FOR  
CHEVRON OIL COMPANY

---

In May 1976, Phoenix Geophysics completed a resistivity survey along four parallel lines approximately 4000 feet apart with 500 foot dipoles in the San Emidio Area. This survey located some shallow, low-resistivity anomalies having a true resistivity of less than two ohm meters.

At the request of Mr. Bob Edmiston, geophysicist for Chevron Oil Company, one additional line was surveyed between and parallel to two of the previously completed lines. The data obtained along this line is prepared for inclusion in the previous report and the plan map, RP-U-5012, has been revised to show all the survey lines in the San Emidio area.

Line SE-76-5 has located a definite anomaly at shallow to moderate depth between 12+50E to beyond the west end of the line. This anomaly corresponds with the anomalous responses located on the adjacent lines and has also located a possible fault in the vicinity of 20E to 25E.

The previous report concluded that some temperature gradient holes should be drilled to determine if this highly conductive area is geothermally active. Several locations for shallow temperature holes were



previously recommended and the data for this line suggests test holes should be considered between 5W to 10W and 15W to 20W.

The zone of low resistivity has not yet been fully outlined. If the results of the temperature gradient holes are encouraging, additional resistivity work may still be required.

PHOENIX GEOPHYSICS INC

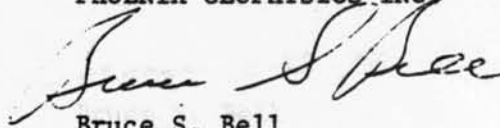

Bruce S. Bell  
Geologist

Dated: August 5, 1976

PHOENIX GEOPHYSICS  
RES STIVITY SURVEY  
PLAN MAP

R. 23 E.

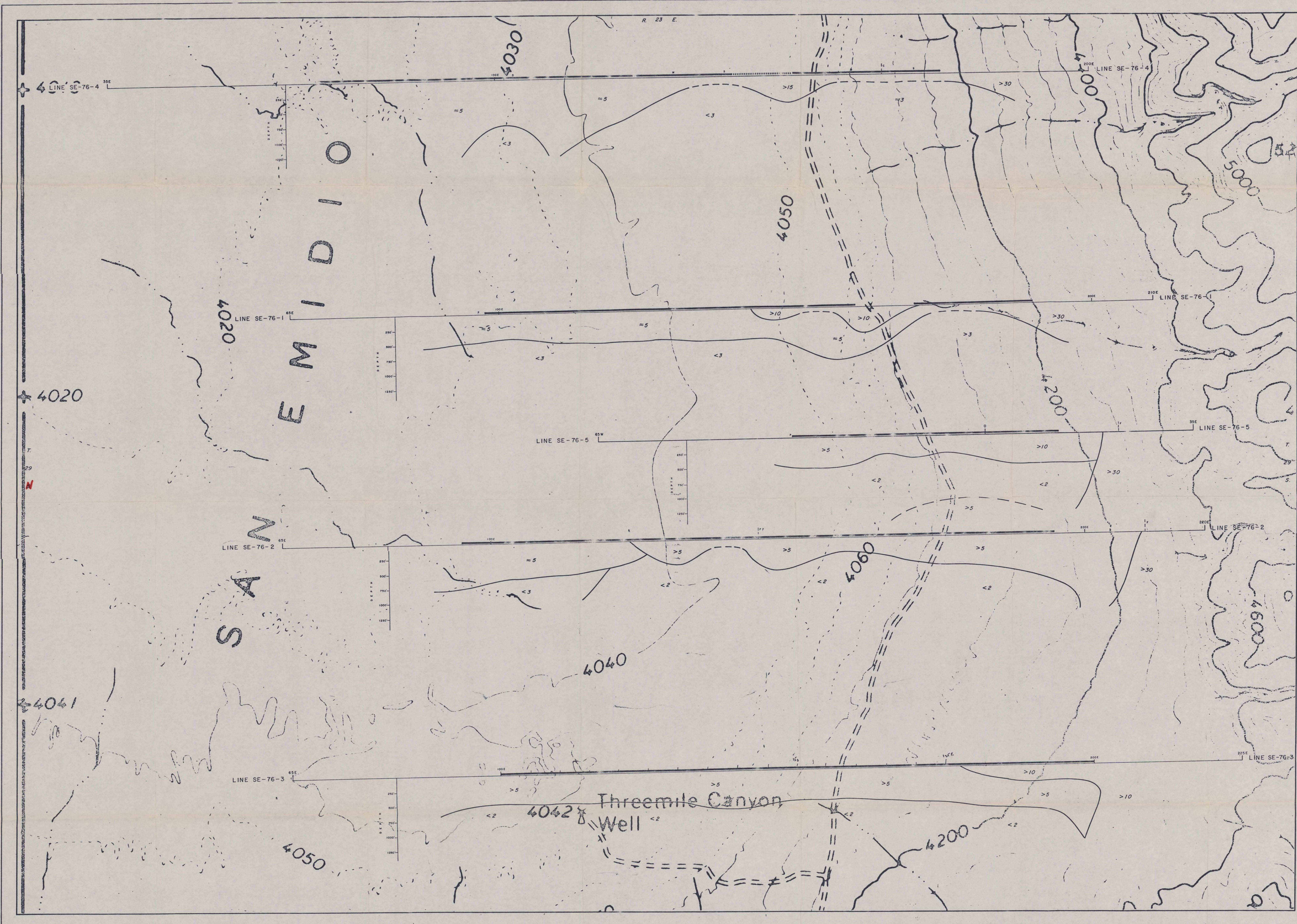

SURFACE PROJECTION OF ANOMALOUS ZONES

DEFINITE ———  
PROBABLE ·······  
POSSIBLE - - - - -  
APPARENT DEPTH  
S = Shallow  
M = Moderate, D = Deep  
C = Contact, F = Fault

NOTE: GENERALIZED RESISTIVITY CROSS SECTION IN OHM-METERS

CHEVRON OIL COMPANY  
SAN EMIDIO AREA, WASHOE COUNTY, NEVADA

SCALE  
FEET 500 0 500 1000 1500 2000 2500 FEET  
1 INCH EQUALS 500 FEET

DRAWN J.R.  
REVISED DATE AUG, 1976  
APPROVED  
DATE 8/5/76

DRAWN J.R.  
DATE JUNE, 1976  
APPROVED  
DATE 7/2/76

L-SE-76-1 65E 70E 75E 80E 85E 90E 95E 100E 105E 110E 115E 120E 125E 130E 135E 140E 145E 150E 155E 160E 165E 170E 175E 180E 185E 190E 195E 200E 205E 210E L-SE-76-1

RESISTIVITY (APP.) IN OHM METERS

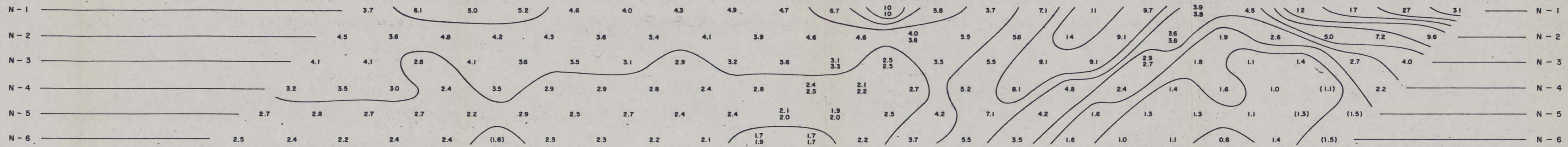

RESISTIVITY (APP.) IN OHM METERS

L-SE-76-2 65E 70E 75E 80E 85E 90E 95E 100E 105E 110E 115E 120E 125E 130E 135E 140E 145E 150E 155E 160E 165E 170E 175E 180E 185E 190E 195E 200E 205E 210E 215E 220E L-SE-76-2

RESISTIVITY (APP.) IN OHM METERS

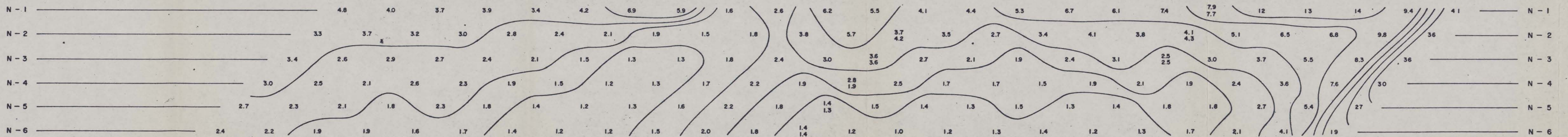

RESISTIVITY (APP.) IN OHM METERS

DWG. NO. - R - U - 5012 - 1

**CHEVRON OIL COMPANY**  
SAN EMIDIO AREA, WASHOE COUNTY  
NEVADA

LINE NO. - SE-76-1 (X = 500 FT.)  
LINE NO. - SE-76-2 (X = 500 FT.)

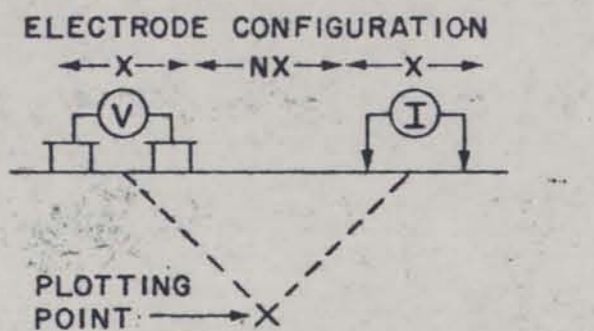

SURFACE PROJECTION OF ANOMALOUS ZONES  
DEFINITE —————  
PROBABLE - - - - -  
POSSIBLE ·······

FREQUENCY: 0.125 HZ. DATE SURVEYED: MAY, 1976

APPROVED: *[Signature]*  
DATE: 7/2/76

NOTE: CONTOURS AT LOGARITHMIC INTERVALS 1 - 1.5 - 2 - 3 - 5 - 7.5 - 10

**PHOENIX GEOPHYSICS**  
RESISTIVITY SURVEY

L-SE-76-3 65E 70E 75E 80E 85E 90E 95E 100E 105E 110E 115E 120E 125E 130E 135E 140E 145E 150E 155E 160E 165E 170E 175E 180E 185E 190E 195E 200E 205E 210E 215E 220E 225E L-SE-76-3

RESISTIVITY (APP.) IN OHM METERS

RESISTIVITY (APP.) IN OHM METERS

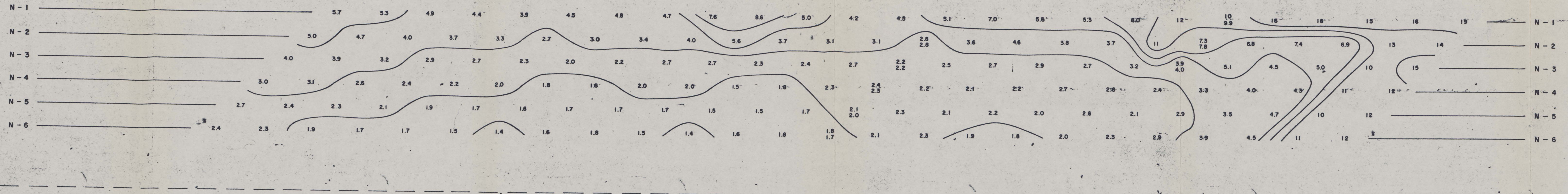

L-SE-76-4 35E 40E 45E 50E 55E 60E 65E 70E 75E 80E 85E 90E 95E 100E 105E 110E 115E 120E 125E 130E 135E 140E 145E 150E 155E 160E 165E 170E 175E 180E 185E 190E 195E 200E L-SE-76-4

RESISTIVITY (APP.) IN OHM METERS

RESISTIVITY (APP.) IN OHM METERS

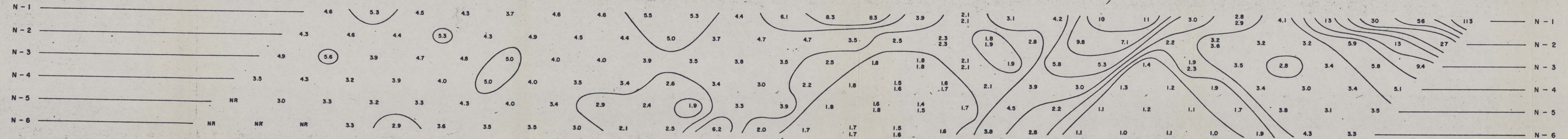

DWG. NO. - R - U - 5012-2

**CHEVRON OIL COMPANY**  
 SAN EMIDIO AREA, WASHOE COUNTY  
 NEVADA

LINE NO. - SE-76-3 (X = 500 FT.)  
 LINE NO. - SE-76-4 (X = 500 FT.)

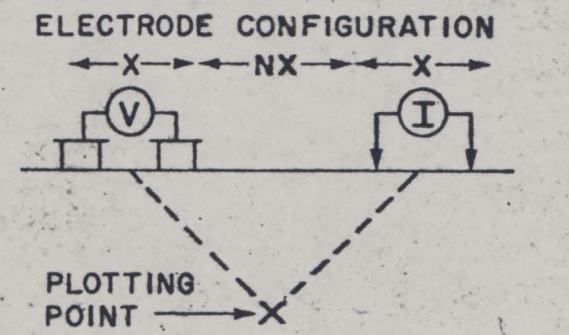

SURFACE PROJECTION  
 OF ANOMALOUS ZONES  
 DEFINITE —————  
 PROBABLE ·········  
 POSSIBLE - - - - -

FREQUENCY: 0.125 HZ. DATE SURVEYED: MAY, 1976

APPROVED: *[Signature]*  
 DATE: 7/2/76

NOTE: CONTOURS AT  
 LOGARITHMIC INTERVALS  
 1.-1.5-2.-3.-5.-7.5-10

**PHOENIX GEOPHYSICS**  
 RESISTIVITY SURVEY

L-SE-76-5 65W 60W 55W 50W 45W 40W 35W 30W 25W 20W 15W 10W 5W 0 5E 10E 15E 20E 25E 30E 35E L-SE-76-5

DWG. NO. - R - U - 5012 - 3

**CHEVRON OIL COMPANY**  
 SAN EMIDIO AREA, WASHOE COUNTY  
 NEVADA

LINE NO. - SE-76-5 (X=500 FT.)

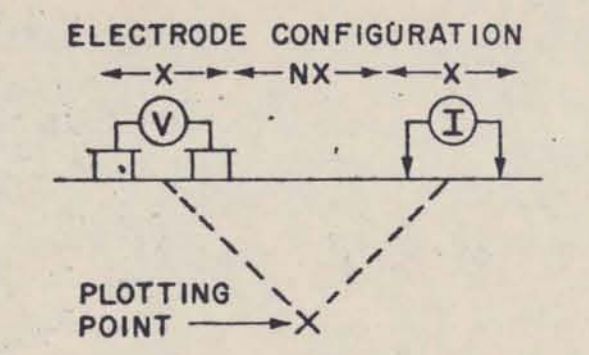
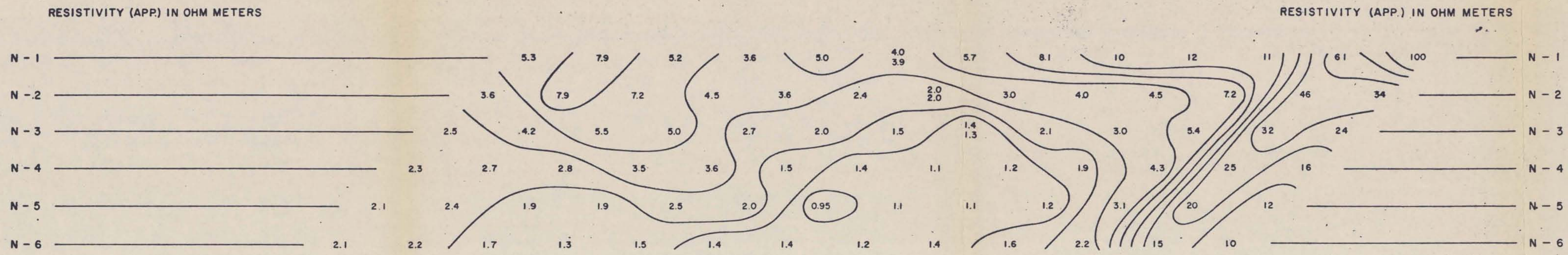

SURFACE PROJECTION  
 OF ANOMALOUS ZONES

DEFINITE —————  
 PROBABLE ·········  
 POSSIBLE / / / / /

FREQUENCY: 0.125 HZ. DATE SURVEYED: JULY, 1976

APPROVED: *[Signature]*

NOTE: CONTOURS AT LOGARITHMIC INTERVALS 1.-1.5-2.-3.-5.-7.5-10 DATE: 8/5/76

**PHOENIX GEOPHYSICS**  
 RESISTIVITY SURVEY